

# LOW VOLTAGE SWITCH ACCESSORIES SELECTION MANUAL

WWW.CHINA-XJ.COM

## 兴机电器集团有限公司

XINGJI ELECTRICAL APPARATUS GROUP CO., LTD

地址：温州市瓯海区娄桥工业区集贤路58号  
NO.58, JI XIAN ROAD, LOU QIAO INDUSTRIAL AREA,  
OU HAI, WEN ZHOU

电话：0577-89763170 886202378 88420889 8625541

传真：0577-88637969 88625542

邮编：325027

邮件：wxjxs@china-xj.com

WWW.CHINA-XJ.COM

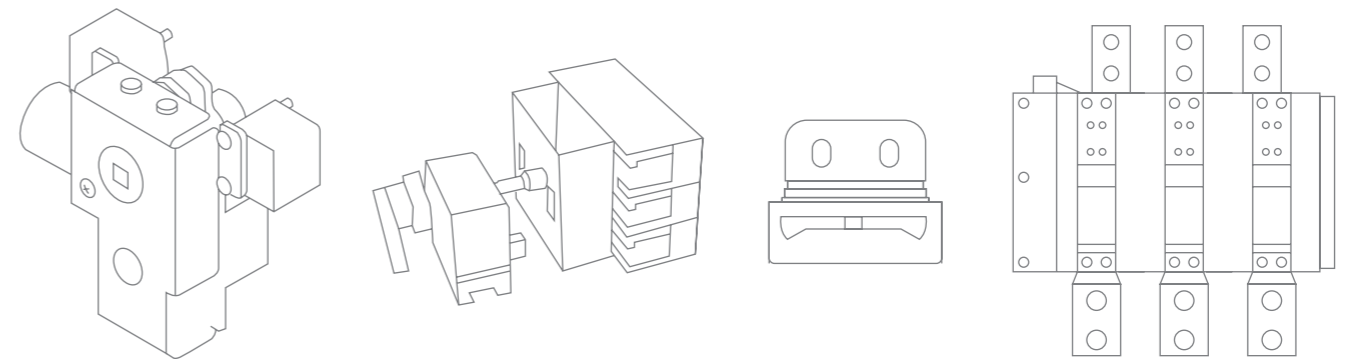

XING JI ELECTRICAL GROUP CO.,LTD.



# CONTENT

## 目录

**002 - 007**

**SKC Low-voltage electric drawer**  
SKC LOW-VOLTAGE  
ELECTRIC DRAWER

**008 - 073**

**Accessories of low-voltage switchgear**  
ACCESSORIES OF  
LV SWITCHGEAR

- 010 - 026 ————— Operation Mechanism
- 027 - 038 ————— Primary Connector
- 039 - 044 ————— Secondary Connectors
- 045 - 051 ————— Circuit Distribution and Transfer Unit
- 052 - 057 ————— Second-Generation Cabinet Accessories
- 058 - 065 ————— Busbar Clamp/Small Busbar Retainer
- 066 - 073 ————— Lock and Other Accessories

**074 - 107**

**8PT/OKKEN/B/P Cabinet accessories**  
8PT/OKKEN/B/P  
CABINET ACCESSORIES

**108 - 137**

**Q Series switchgear**  
Q SERIES  
SWITCHGEAR

WWW.CHINA-XJ.COM

XING JI ELECTRICAL GROUP CO.,LTD.

# SKC LOW-VOLTAGE ELECTRIC DRAWER

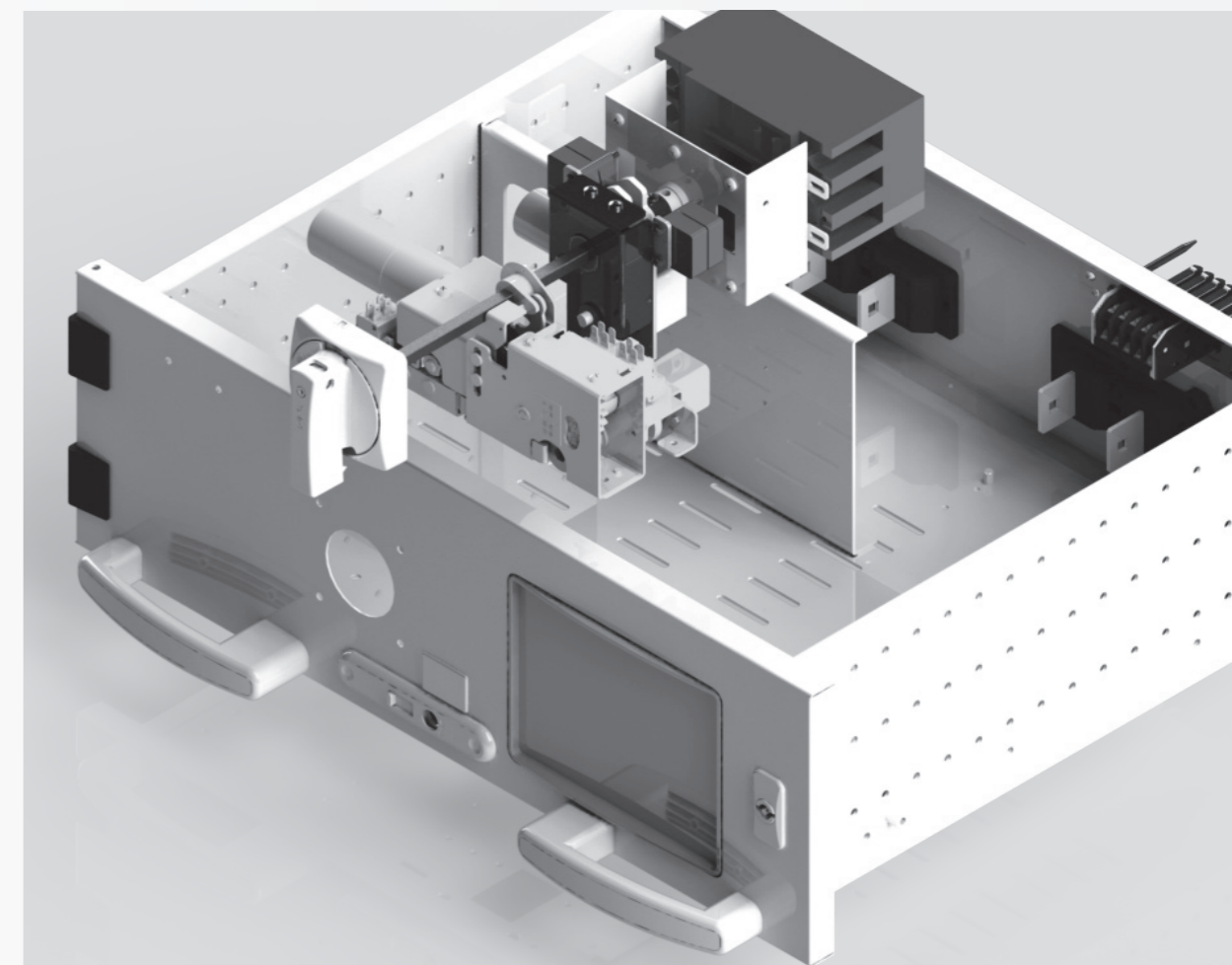





# ACCESSORIES OF LV SWITCHGEAR

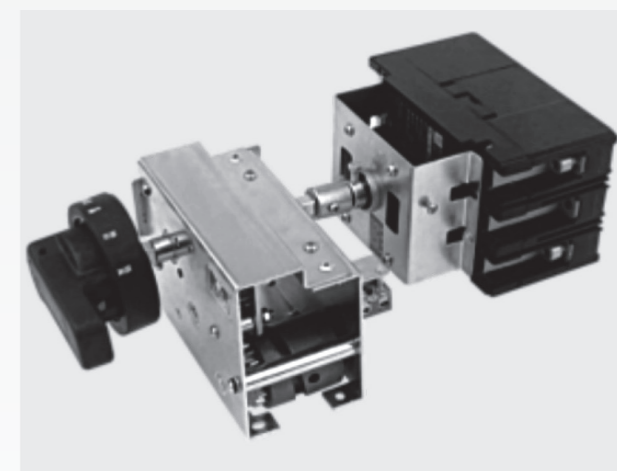
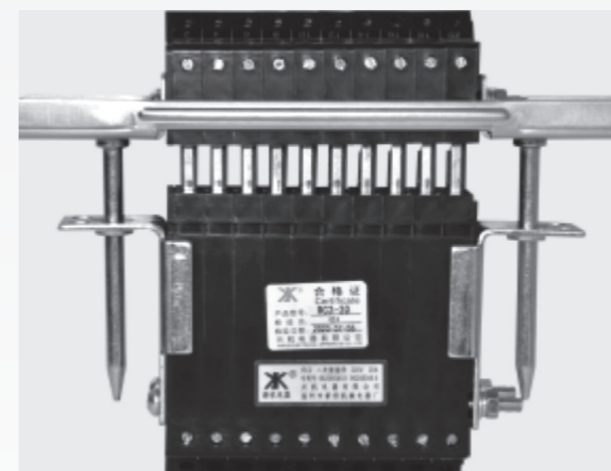



























































































































# HH15P-630、1000/4 Isolating Switch

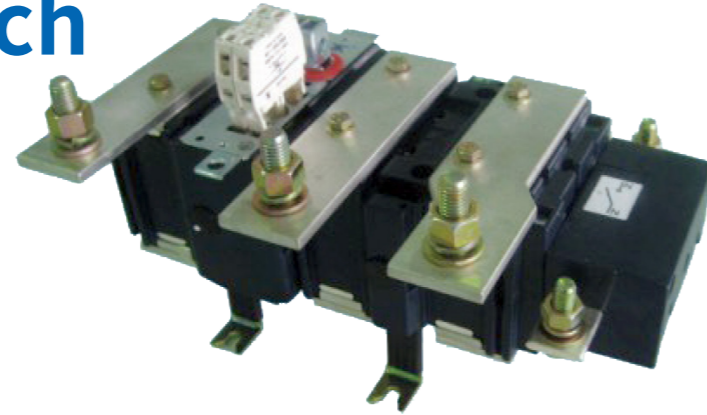

HH15P(QP) Isolating Switch

## Dimensions

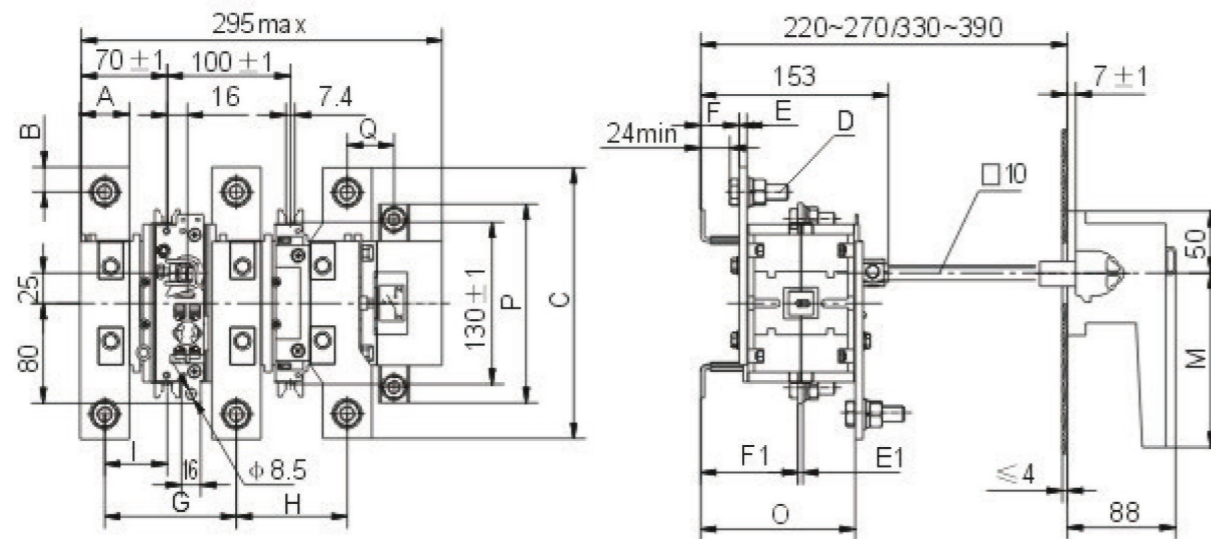

## Primary Technical Parameters

Code Type	A	B	C	D	E	F	G	H	I	M	E1	F1	P	Q	O	L
HH15P-630/4	30	15	170	M10	5	39	107	65	43.5	140	4	79	160	56	119	220-270/ 330-390
HH15P-1000/4	40	20	218	M12	6	32	117	80	51	140	4	79	160	38.5	125	

# HH15P-1250、1600/3 Isolating Switch

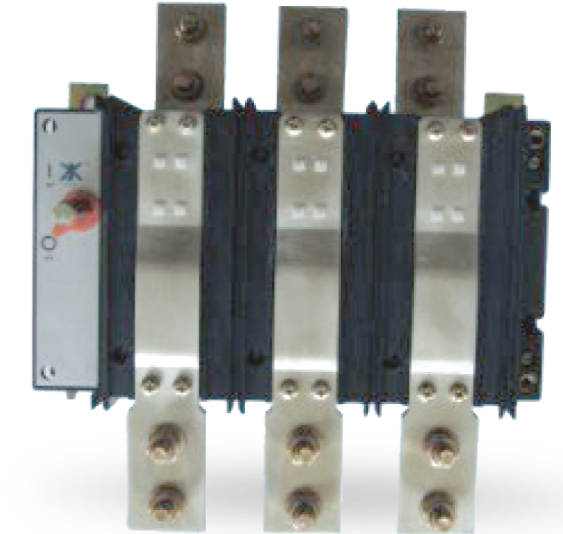

HH15P(QP) Isolating Switch

## Dimensions

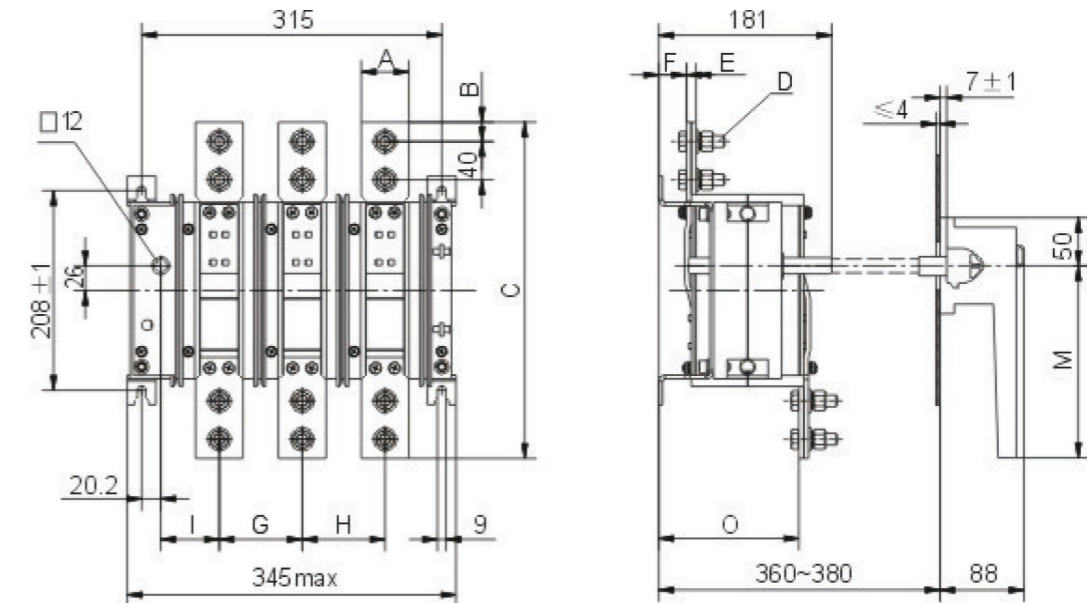

## Primary Technical Parameters

Code Type	A	B	C	D	E	F	G	H	I	M	O	L
HH15P-1250/3	40	20	350	2-M2	10	29	87	87	60	200	147	360-380
HH15P-1600/3	50	20	350	2-M12	10	22	87	87	60	200	147	

# HH15A-1000/3 Isolating Switch

HH15P(QP) Isolating Switch



## Dimensions

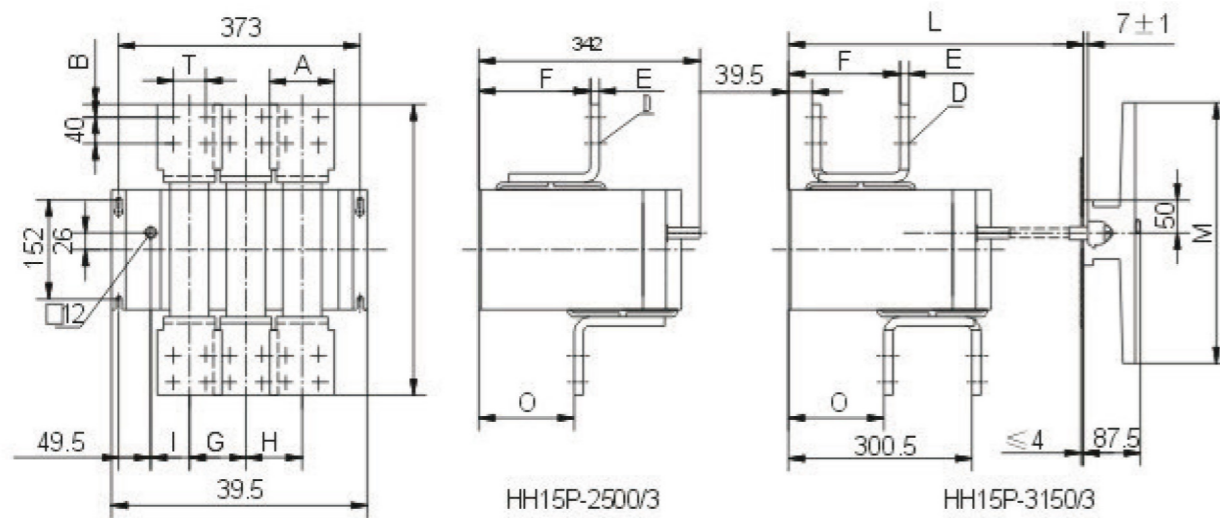

## Primary Technical Parameters

Code Type	A	B	C	D	E	F	G	H	I	M	O	T	L
HH15P-2500/3	80	20	446	4-M12	12.5	171.5	100	100	47	400	170	40	450-490
HH15P-3150/3	100	20	462	4-M12	14	172.5	87	87	60	400	167.5	50	

# HH15S、HH15AS、HH15PS Changeover switch for double isolating switches mechanism

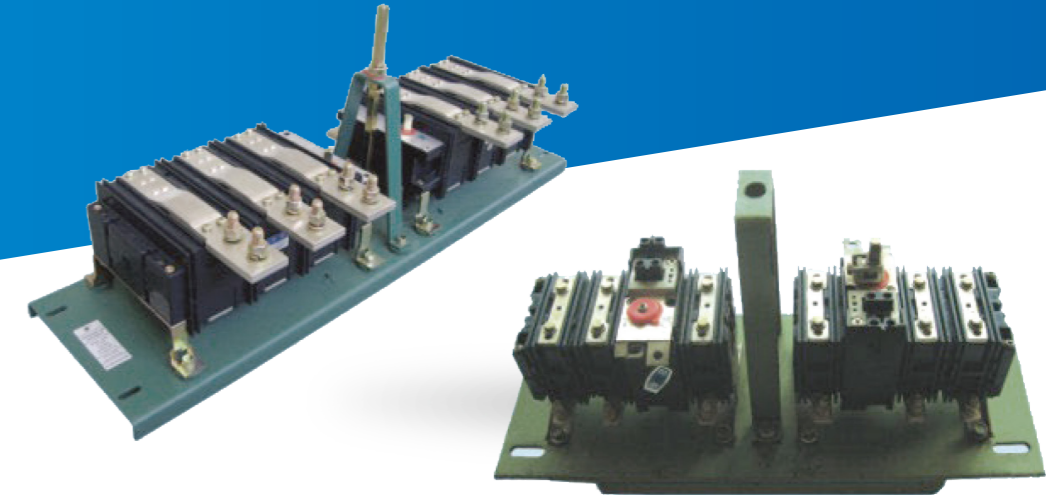

## Dimensions

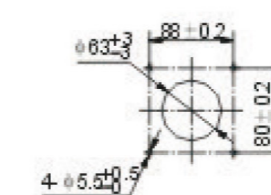
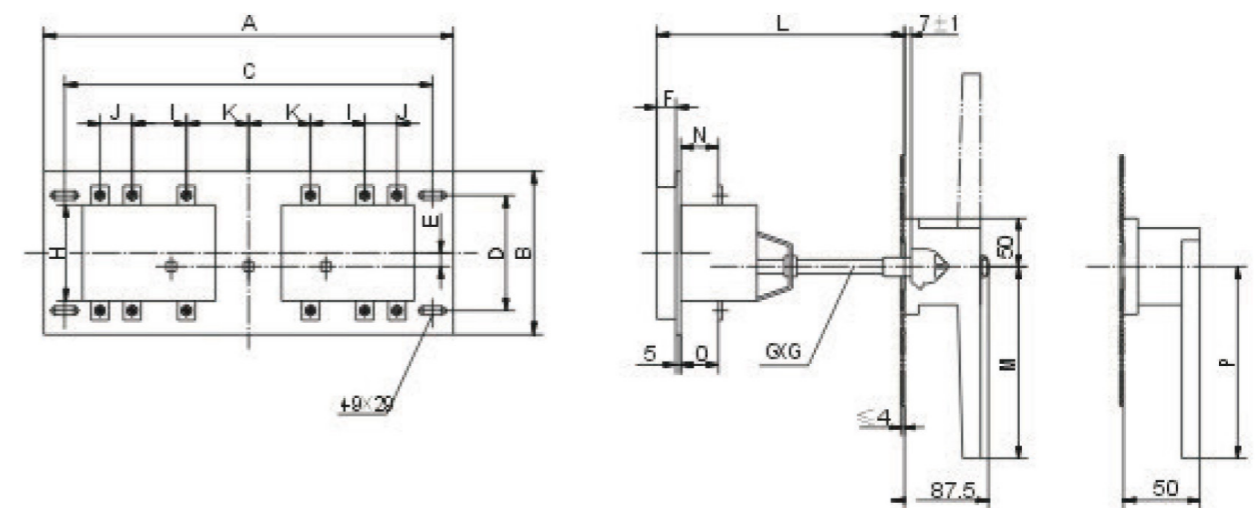

H型手柄面板开孔尺寸

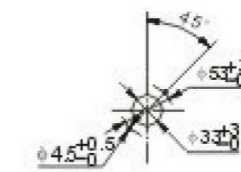

B型手柄面板开孔尺寸



## Primary Technical Parameters

Code Modle (2P/3P/4P)	A	B	C	D	E	F	G	H	I	J	K	L	M	N	O	P
HH15S(QSS)-63	430	170	386	120	14	20	10	100	72	38.5	41.5	260	140	39.5	39.5	126
HH15S(QSS)-125 HH15AS(QAS)-125	430	170	386	120	14	20	10	116	70	40.5	42.5	260	140	38.5	38.5	126
HH15AS(QAS)-160 HH15AS(QAS)-200	430	170	386	120	14	20	10	127	65	45.5	45.5	260	140	38.5	38.5	126
HH15PS(QPS)-250	430	170	386	120	14	20	10	143	66	44.5	45	260	140	37.5	99	126
HH15S(QSS)-160	630	190	580	120	25	20	10	146	107	65	48	300	200	44	44	126
HH15S(QSS)-250 HH15AS(QAS)-400	630	190	580	120	25	20	10	160	107	65	50.5	300	200	40	40	126
HH15S(QSS)-400	630	190	580	120	25	20	10	160	107	65	50.5	300	200	38	38	126
HH15AS(QAS)-630	630	190	580	120	25	20	10	180	107	65	50.5	300	200	38	38	126
HH15PS(QPS)-630	630	190	580	120	25	20	10	70	107	65	50.5	300	200	39	119	126
HH15PS(QPS)-1000	630	190	580	120	25	20	10	218	117	80	43	300	200	32	125	126
HH15S(QSS)-630 HH15AS(QAS)-1000	950	265	906	180	28	23	12	270	87	87	147.5	370	200	33	33	180
HH15PS(QPS)-1250 HH15PS(QPS)-1600	950	265	906	180	28	23	12	350	87	87	147.5	370	200	29	147	180
HH15PS(QPS)-2500	950	265	906	180	28	23	12	446	100	100	134.5	450	400	171.5	170	
HH15PS(QPS)-3150	950	265	906	180	28	23	12	462	87	87	147.5	450	400	172.539.5	167.5300.5	



# XING JI HONOR

公司荣誉

资质认证  
Qualification Certification

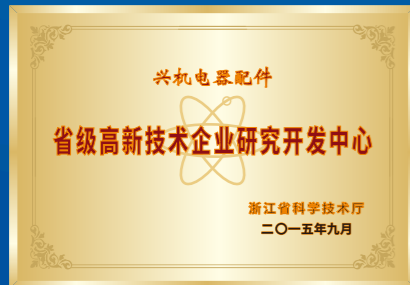
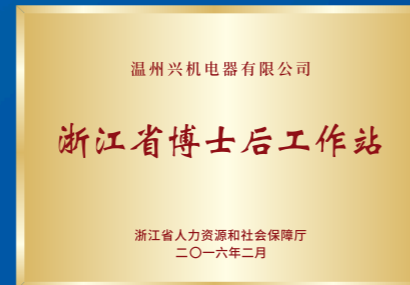
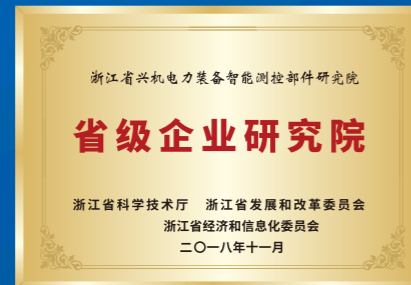
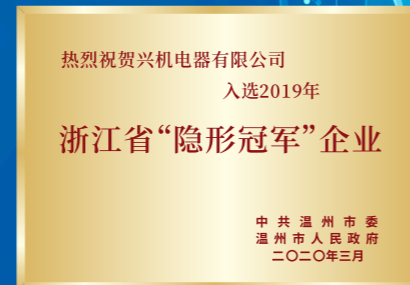
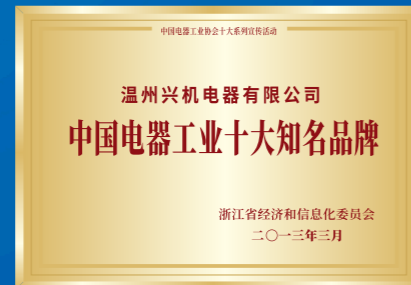
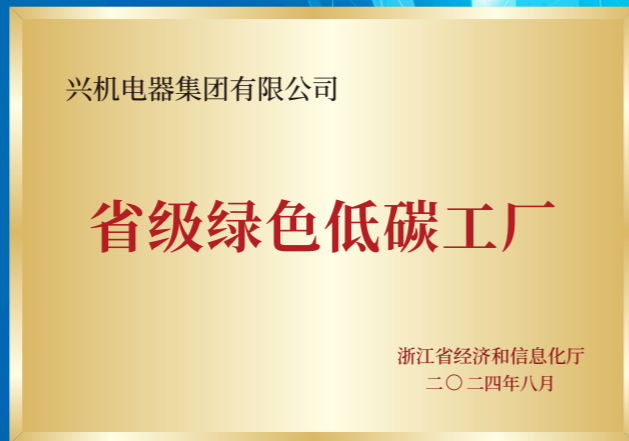
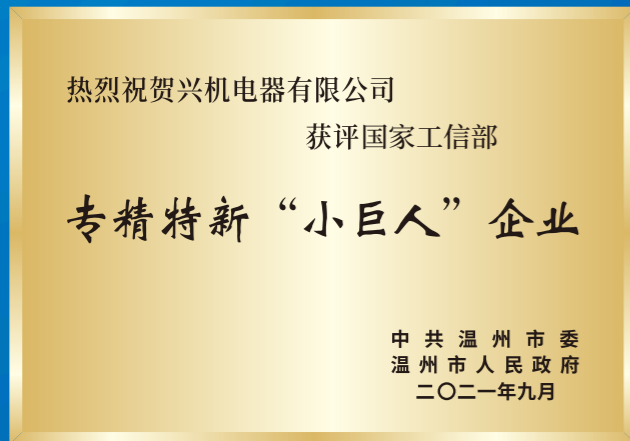

01	02	03	04
中国机械工业科学技术奖 China machinery industry science and Technology Award	浙江省服务型制造示范企业 Zhejiang service-oriented manufacturing demonstration enterprise	企业信用评价AAA级信用企业 Enterprise Credit Evaluation AAA credit enterprise	温州市关键技术攻坚示范企业 Wenzhou key technology demonstration enterprise
05	06	07	
温州市级研发投入优秀企业 Wenzhou credit management demonstration enterprise	浙江省级工业互联网平台优秀企业 Excellent enterprise of Zhejiang Provincial Industrial Internet platform	温州市信用管理示范企业 Wenzhou Municipal R & D investment excellent enterprise	

